



The profile BAI is ideal for sealing reciprocating actuator rods.

Features

- Heavy dynamic lip (inside) ensures longest life.
- Short, wiper-type dynamic lip reduces frictional forces due to hydrostatic pressure.
- Helical spring for high load and small deflection range.
- Squared, long static lip stabilizes the seal.
- Widest range of cross-sections and diameters available, including sizes for upgrading standard O-ring grooves.
- Many high-resilience energizer options available, including choice of light, medium and heavy loads and NACE for oil field use.
- Low-cost elastomeric energizers available, all with excellent fatigue resistance.

Range of Application

For reciprocating rod sealing.

Operating pressure	≤ 20 MPa
Operating temperature	-260 to +315 °C
Surface speed	≤ 15 m/s

Compounds

The BAI seal is available in a wide range of polymers. These include unfilled PTFE, filled PTFE, UHMW-PE and many others. See the compound list for further information.

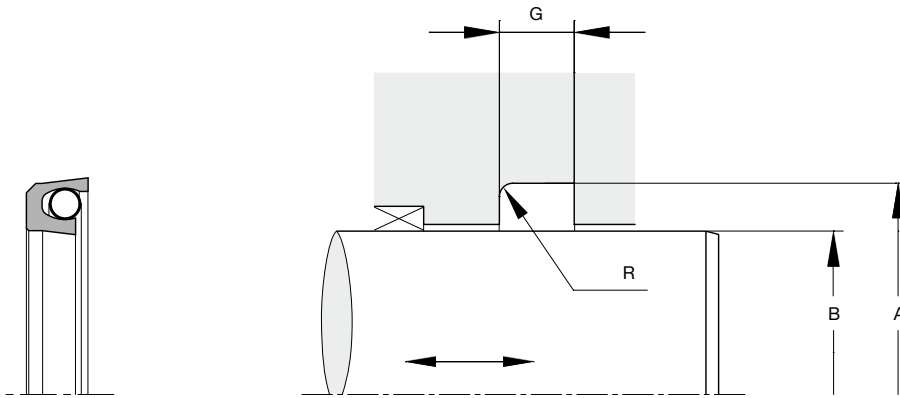

Housing dimensions

Nominal cross-section	Cross-section code	Recommended inner Ø range		Outer Ø	Groove width min.	Radius max.
		Tolerance h8 B (mm)				
		≥	≤			
1/16"	01	7.5	75	B + 2.84	2.4	0.30
3/32"	02	5.5	180	B + 4.52	3.6	0.50
1/8"	03	6.0	250	B + 6.15	4.8	0.50
3/16"	04	12.5	300	B + 9.45	7.1	0.75
1/4"	05	50.0	500	B + 12.12	9.5	0.75
3/8"	06	150.0	1400	B + 18.75	13.3	0.75
1/2"	07	300.0	3000	B + 25.40	18.0	0.75

FlexiSeal®

Ordering example

Rod 70 mm
Cylinder bore 76.15 mm

BAI M007000 03 XXX Y

BAI profile
M007000 inner groove diameter in mm times 100
03 cross-section code corresponding to a 6.15 mm groove diameter difference
XXX jacket material
Y spring-energizer material